



Article : Torque Head
Model No : OE 55-SP
A/F Size : 55mm
Type of Drive : Open End
Type of Attachment : Dovetail
Centreline : 3.7/8" in centerline
Torque : 400 Nm
Suitable for Sturtevant Richmond LTC Series
Preset, SLTC Series Switch & Exacta Series
Digital Torque Wrenches.



Article : Torque Head
Model No : OE 36-SP
A/F Size : 36mm
Type of Drive : Open End
Type of Attachment : Dovetail
Centreline : 1.7/16" in centerline
Torque : 325 Nm
Suitable for Sturtevant Richmond LTC Series
Preset, SLTC Series Switch & Exacta Series
Digital Torque Wrenches



Article : Torque Head
Model No : BH 15/16-OS
A/F Size : 15/16"
Type of Drive : Offset Box head Drive
Type of Attachment : Dovetail
Centreline : 4" in centerline
Torque : 190 Nm
Suitable for Sturtevant Richmond LTC
Series Preset, SLTC Series Switch & Exacta
Series Digital Torque Wrenches



Tel: (022)- 27566533/ 27566534 Fax: +91- 22 -27566534 e-mail: westec@vsnl.com
website: www.westec-india.com

SPECIAL OFFSET BH - 15/16" HEAD WITH 3-7/8" CENTRE LINE DEVELOPED FOR JOHN DEERE





WESTEC

Tel: (022)- 27566533/ 27566534 Fax: +91- 22 -27566534 e-mail: westec@vsnl.com
website: www.westec-india.com



Article : Torque Head
Model No : OE 36-SP
A/F Size : 36mm
Type of Drive : Open End
Type of Attachment : Dovetail
Centreline : 1.7/16" in centerline
Torque : 325 Nm
Suitable for Sturtevant Richmond LTC Series Preset,
SLTC Series Switch & Exacta Series Digital Torque
Wrenches

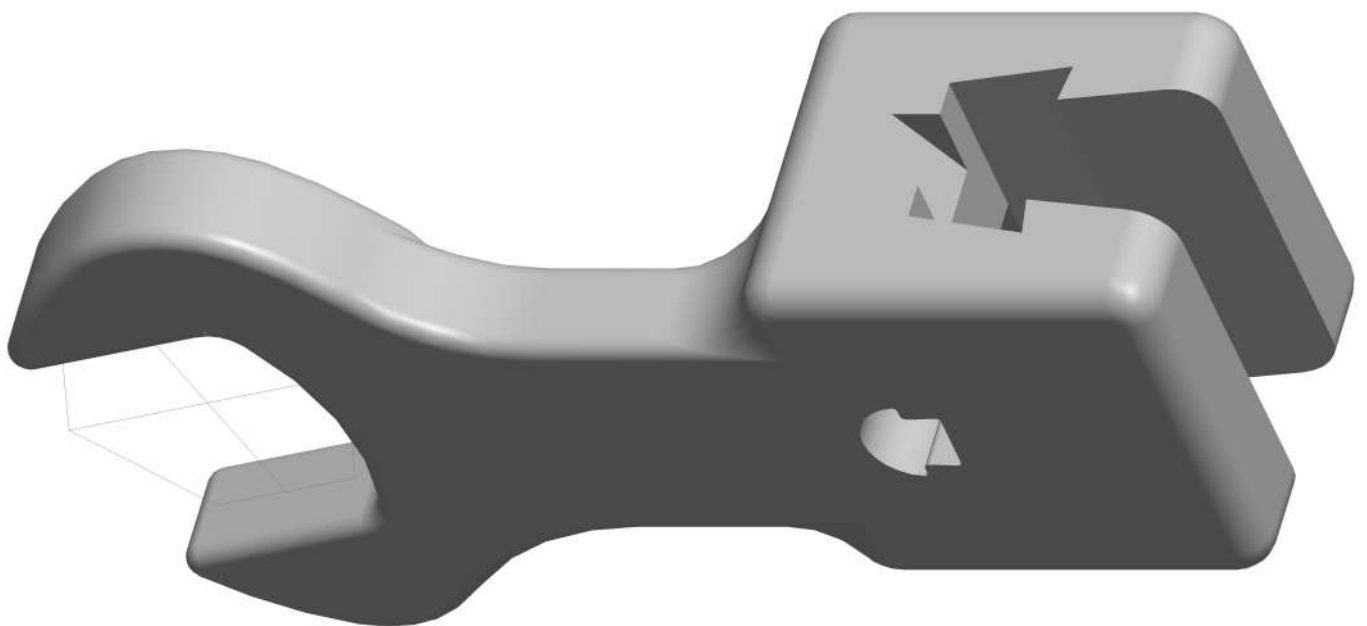
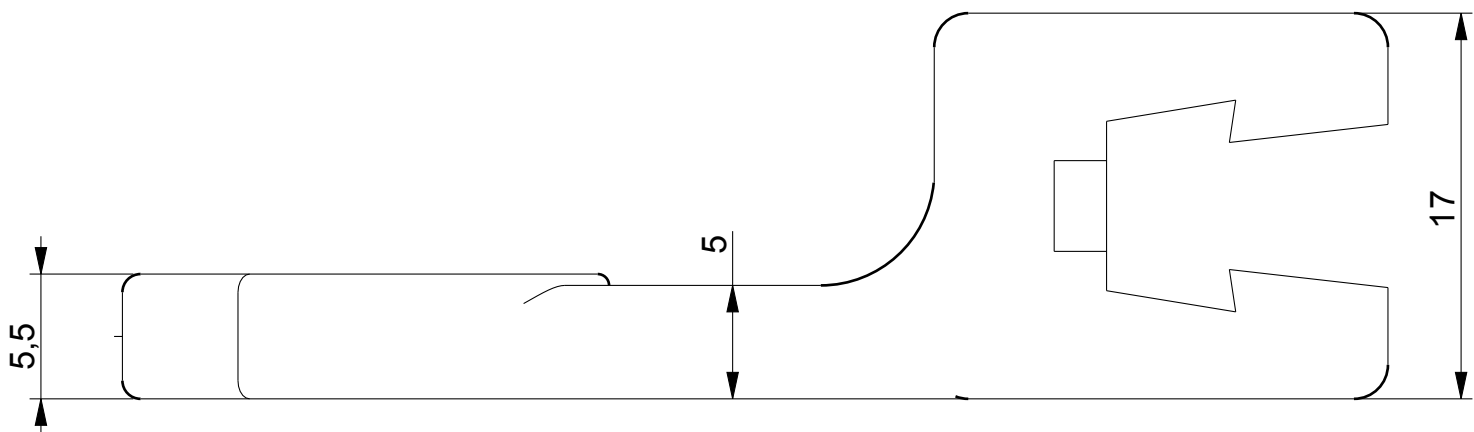
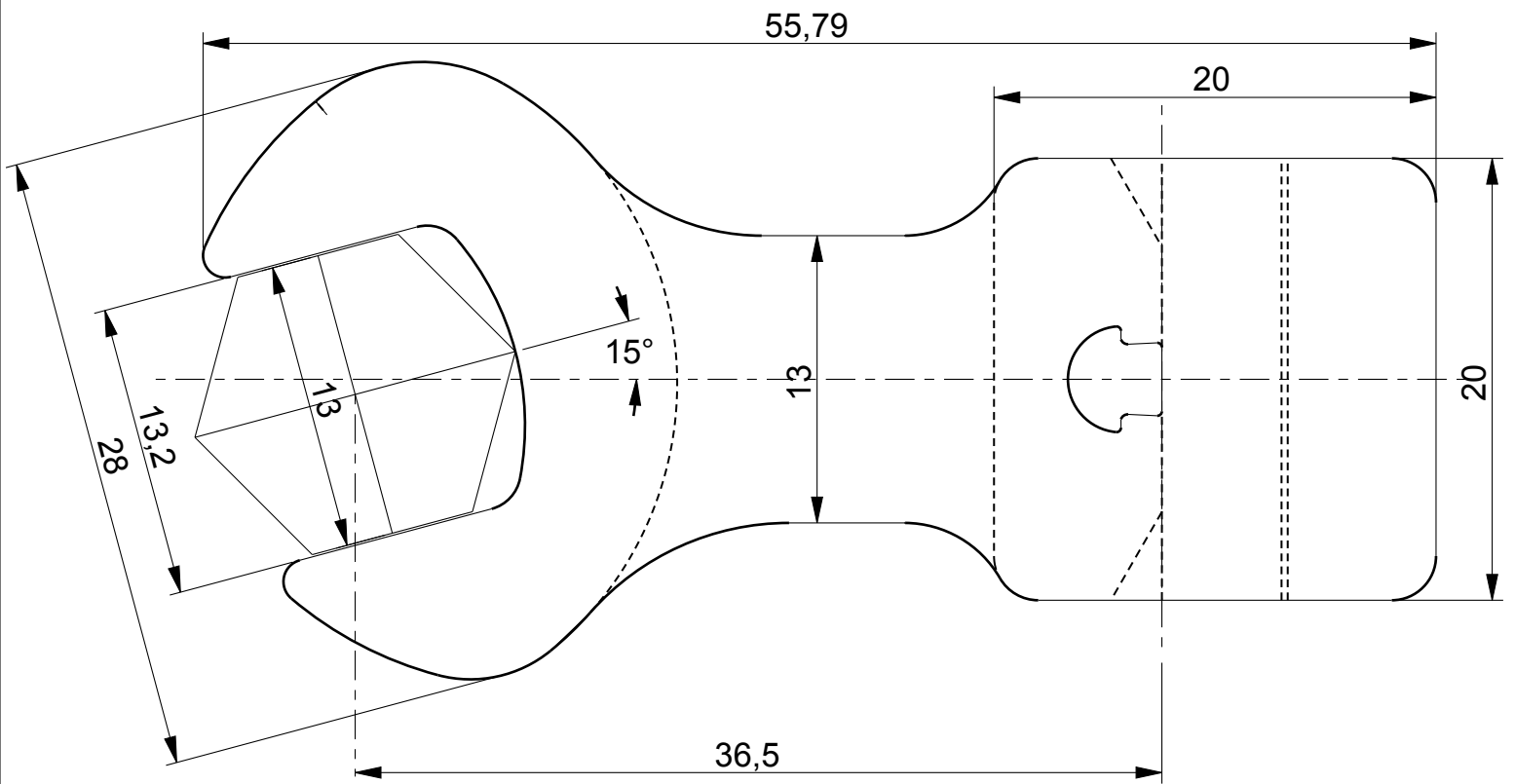

SCALE 3,000

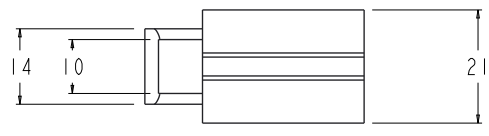
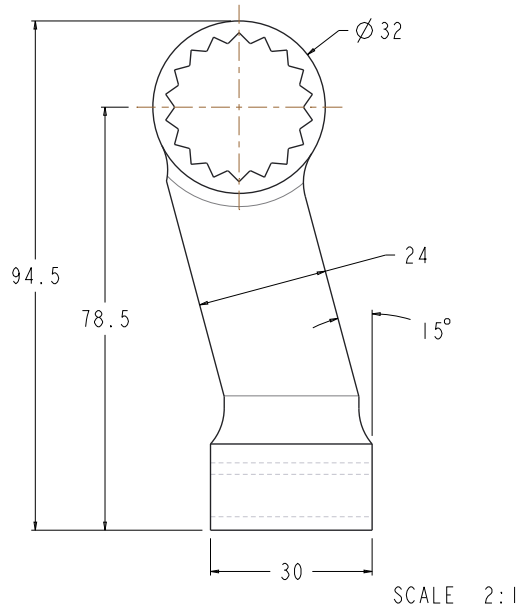

MATERIAL: CHROME MOLYBDENUM STEEL

REV	BY	DATE	SHEET	DECISION	REVISION
A					NEW

UNSPECIFIED TOLERANCES SHOWN AS BELOW			
MACHINING DIMENSIONS:	NON-MACHINED DIMENSIONS:		
UP TO 25 mm	±0.1	UP TO 25 mm	±0.5
OVER 25 UP TO 100 mm	±0.2	OVER 25 UP TO 100 mm	±1
OVER 100 UP TO 300 mm	±0.3	OVER 100 UP TO 300 mm	±1.5
OVER 300 mm	±0.4	OVER 300 mm	±2

ORIGINAL PART NO.	DEERE & COMPANY MOLINE, ILLINOIS 61265
DESIGN CONTROL:	CONFIDENTIAL AND PROPRIETARY TO DEERE & COMPANY. UNAUTHORIZED USE, DISCLOSURE, OR REPRODUCTION PROHIBITED. COPYRIGHT © DEERE & COMPANY. ALL RIGHTS RESERVED.
DATE	
DRAWN	
CHECKED	
SCALE	1:1
TOLERANCES DO NOT ACCUMULATE; DO NOT SCALE DRAWING FOR DIMENSIONS.	SHEET NO. 1 OF 1
METRIC	MASS: KG=0.2 SHEET SIZE: A2
TOOL DESCRIPTION	TOOL NUMBER LL_ASM

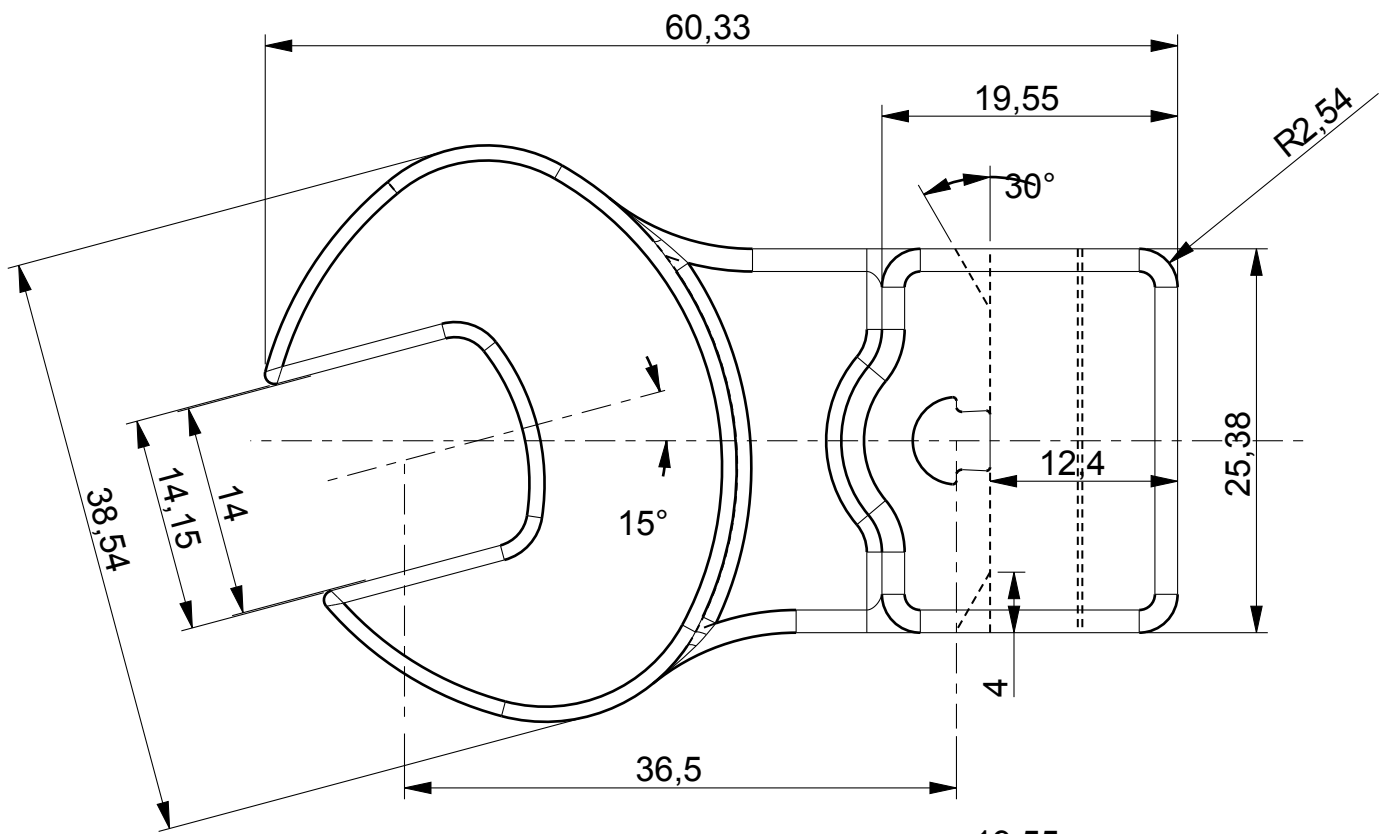

SCALE 2,000

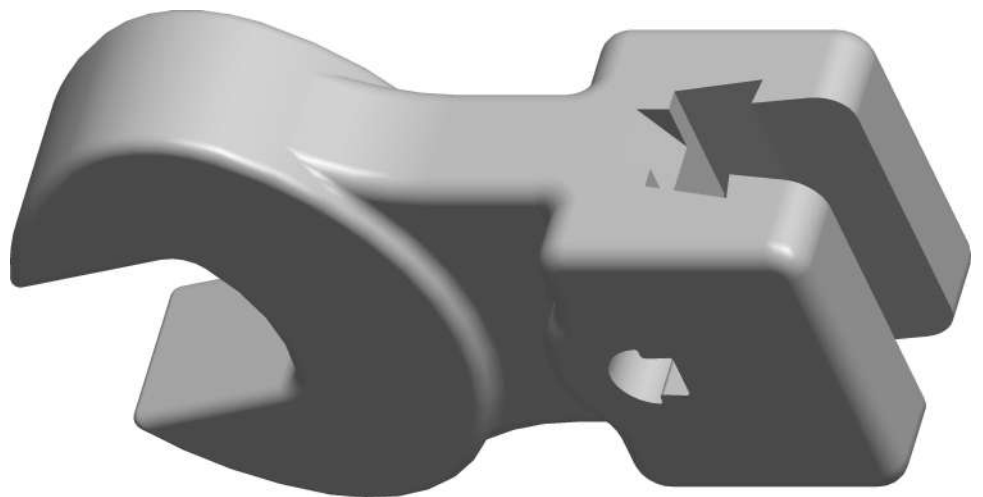
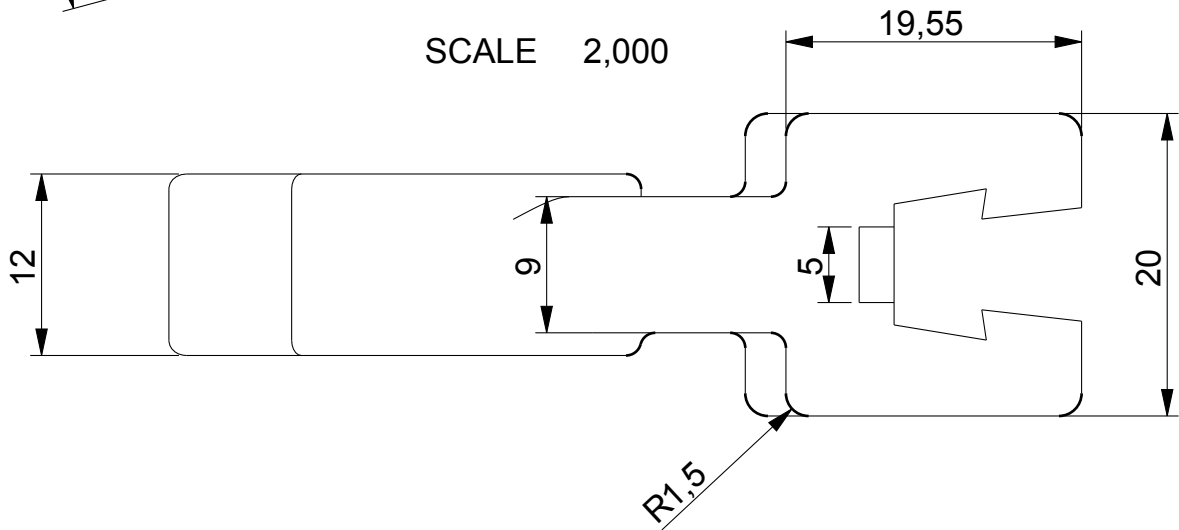

SCALE 2,000

OE-14

WESTEC[®] - Sales & Services In India

Office No. 12, 1st Floor, Hermes Atrium,
B wing, Plot 57, Sector – 11,
CBD Belapur, Navi Mumbai – 400 614

Mob: 9821 0327 20 | Tel:+91-22-2756 6533
Telefax: +91-22-2756 6534 | Website - <http://westec-india.com/>
E-mail: westecnavimumbai@vsnl.net