

REACTION ARMS



Folding and Linear Torque Reaction Arm Series

Linear arms manoeuvre smoothly as they absorb the torque reactions from the screwdrivers providing ergonomic support for the operator. The fluid movement increases precision and production for a variety of torque applications. Linear arms keep the tool perpendicular and prevent cross threading and side load. They reduce RMI (Repetitive Motion Injury) and CTS (Carpal Tunnel Syndrome) while boosting production. Each model extends in horizontal direction and arm length is adjustable.

A diameter reduction adapter (code 234545) is available for our PLUTO35 and PLUTO50 screwdriver (Ø 57 mm).

Torque reaction arm PA2KOL, code 010600, has been designed to eliminate the reaction generated by screwdrivers when they stop at the pre-set torque. Options include table or wall mount.

Model	Code	Max Torque Nm	Min Reach mm	Max Reach mm
PA2KOL	010600	20	440	640
LINAR1	010681	25	184	665
LINAR2	010682	50	184	665
LINART	010683	25	114	740

TELESCOPIC TORQUE REACTION ARMS

Telescopic Arm Series

CAR series torque reaction arms are designed to eliminate the reaction that screwdrivers generate when they stop at the preset torque (up to 50 Nm). Their carbon structure makes them extremely lightweight and incredibly resistant at the same time. This means that they resist degradation in high fatigue applications much better than conventional materials. A diameter reduction adapter (code 234545) is available for our PLUTO35 and PLUTO50 screwdriver (Ø 57 mm).

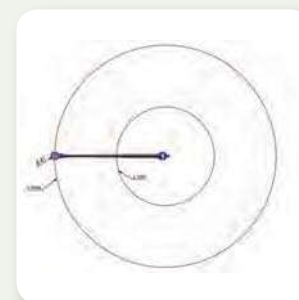
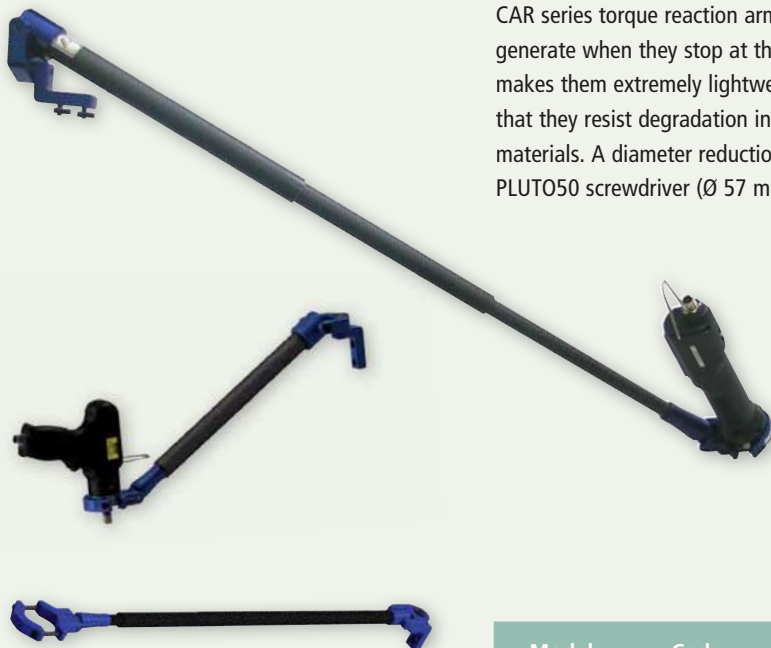

Model	Code	Min Reach (L min) mm*	Max Reach (L max) mm*	Weight kg	Max Torque Nm
CAR101	010661	549	906	0,25	10
CAR281	010663	490	950	0,60	25
CAR282	010664	730	1650	0,75	25
CAR501	010665	490	950	0,65	50
CAR502	010666	730	1650	0,80	50

* Measured with clamp Ø 47 mm

Suspended Torque Arm Series

The new Suspended Torque Arms are the ideal solution to increase productivity. They can be easily installed on most workplaces to help the operator handle the screwdriver in total safety and stability:

- With minimized reaction force you will also improve finished product quality because there is no movement of the tool and all torque is absorbed in the joint.
- Improve the comfort of the operator and the productivity clearing the work area.

Three models available, depending on the motion of the axes:

- SAR15 Z -> Z Axis
- SAR15 XZ 85 -> XZ Axes
- SAR15 XYZ 855 -> XYZ Axes

The new arms are supplied without tool holder - to be purchased depending on the screwdriver:

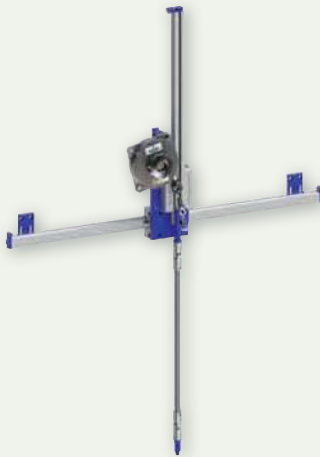

*TOOL HOLDER FOR PLUTO
INLINE*



*TOOL HOLDER FOR PLUTO
WITH ANGLE HEAD*



*UNIVERSAL TOOL HOLDER
FOR ANY SCREWDRIVER*

Model	Code	Vertical Stroke "Z" (mm)	Horizontal Stroke "X" (mm)	Lateral Stroke "Y" (mm)	Max Torque Nm
SAR15 Z	010690/Z/5	364	/	/	15
SAR15 XZ 85	010690/XZ/85	364	692	/	15
SAR15 XYZ 855	010690/XYZ/855	885	692	376	15
Tool holder for PLUTO inline		010695	For any PLUTO..D, PLUTO..FR, PLUTO..D/TA and RAF..NS/FR		
Tool holder for PLUTO w/angle head		010695/P	For any PLUTO..ANG		
Universal Tool Holder		010695/UNI	For any screwdriver (max diameter 47 mm)		

WESTEC[®] - Sales & Services In India

Office No. 12, 1st Floor, Hermes Atrium,
B wing, Plot 57, Sector – 11,
CBD Belapur, Navi Mumbai – 400 614

Mob: 9821 0327 20 | Tel:+91-22-2756 6533
Telefax: +91-22-2756 6534 | Website - <http://westec-india.com/>
E-mail: westecnavimumbai@vsnl.net