

2.5 Connecting Peripheral Devices

The PTV-FM has a 19-pin connector on the side of the box that provides the ability to control or integrate with peripheral devices. This capability is provided through the use of relays triggered by specific subsequent events. The ability to switch among the four parameters on the PTV-FM is provided, and can be triggered by external events when the I/O port is used.

The diagram shows the PTV-FM wiring in the condition in which it is shipped. The two jumper switches, labeled "JP3" and "JP5" are open; current cannot flow through them from the 24VDC internal power supply. To close these switches and access the power from the 24VDC internal power supply you must use the procedure that follows.

The switches can be used with an external power source or the internal power source. When using an external power source, the connectors and their ratings are those given in Table 1 of this section of the manual. To use the internal power source - the accessible 24VDC power supply inside the unit - the connectors and their ratings are those given in Table 2 of this section. This can only be done after following the procedure for installing the jumpers.

It is very important that the ratings in the two tables not be exceeded. Doing so will cause malfunctions and may cause electrical hazards.



Electric Diagram

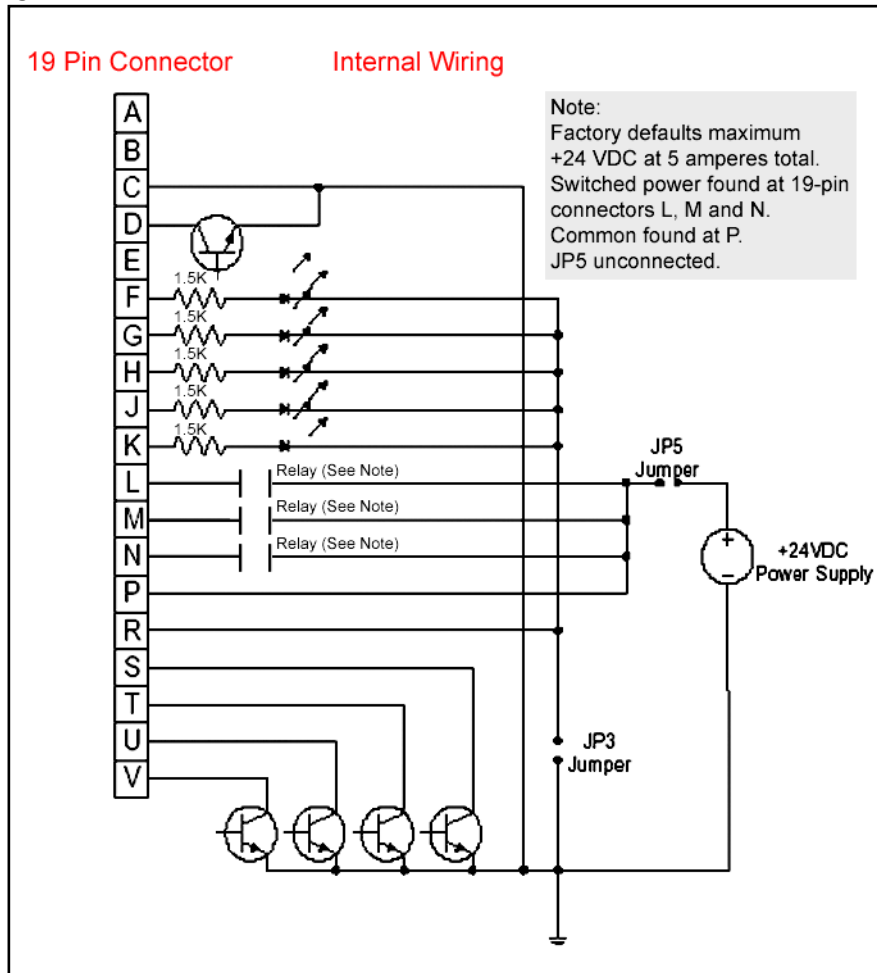

Table 1 - Jumpers JP3 and JP 5 Open - No Current Flows Through Them - As Supplied

<u>Connector Use</u>	<u>Connector Letter</u>	<u>Minimum & Maximum Ratings</u>
Unused	A	No Connection
Unused	B	No Connection
Ground (DC)	C	System DC Ground
Output in Cycle	D	NPN sinking output, see Note A for this table.
Unused	E	Not Connected
Remote Batch Reset	F	12 VDC to 24 VDC optically isolated input, grounded to pin "R" of this connector.
Remote Suspend	G	12 VDC to 24 VDC optically isolated input, grounded to pin "R" of this connector.
Remote Parameter B	H	12 VDC to 24 VDC optically isolated input, grounded to pin "R" of this connector.
Remote Parameter C	J	12 VDC to 24 VDC optically isolated input, grounded to pin "R" of this connector.
Remote Parameter D	K	12 VDC to 24 VDC optically isolated input, grounded to pin "R" of this connector.
Cycle Accept (Relay)	L	Switch contact to "P" of this connector.
Batch Accept (Relay)	M	Switch contact to "P" of this connector.

Reject (Relay)	N	Switch contact to "P" of this connector.
External Relay Common	P	0 to 48V AC or DC power output maximum 5 Amperes
Remote Input Common	R	Common External DC Ground for: F, G, H, J and K
External DC Ground		
Cycle Accept (NPN)	S	NPN sinking output, see Note A for this table.
Batch Accept (NPN)	T	NPN sinking output, see Note A for this table.
Reject (NPN)	U	NPN sinking output, see Note A for this table.
Suspend (NPN)	V	NPN sinking output, see Note A for this table.

Note A for Table 1:

Maximum power must not exceed 1.5W combined.

Formula: Volts * Amperes * number of inputs < 1.5 Watts

Maximum individual input: 48 VDC at 30 mA

Procedure for Closing Jumper Switches JP3 and JP5 and Use the 24VDC Internal Power Supply

1. Disconnect the PTV-FM 2.4 GHz unit from all power sources.
2. Obtain a pair of needlenose (tapered jaw) pliers and a 2mm hex key.
3. Place the unit faceplate up on a stable work surface as shown.
4. The front cover for the unit is held in place by four (4) short screws, as indicated by the arrows in this image.



5. Use the 2mm hex key to remove the screws. Set screws aside for later use in reassembling the unit.



6. Gently lift the front of the box off the remaining five sides. Turn the front over and set it down out of the way as shown in this image. Exercise care in moving the front panel of the box; the wiring connectors can come loose or be damaged if stretched or if the wires are pulled on.



The JP3 and JP5 jumpers are located in the lower-left quadrant of the unit when it is placed as shown in the preceding image. They are immediately to the left of the row of five (5) resistors. The arrows in the image to the right show the location of each. The markings for each jumper are partially hidden by the edge of the jumper in the disconnected (open) position for these switches. There are two jumper leads for each jumper. In this image you can see that the plastic jumper for each switch is covering one lead and one lead is not inserted, placing the switch in the “open” position. The jumper for each switch must be removed from the current position and reinstalled so both leads are connected by the jumper.

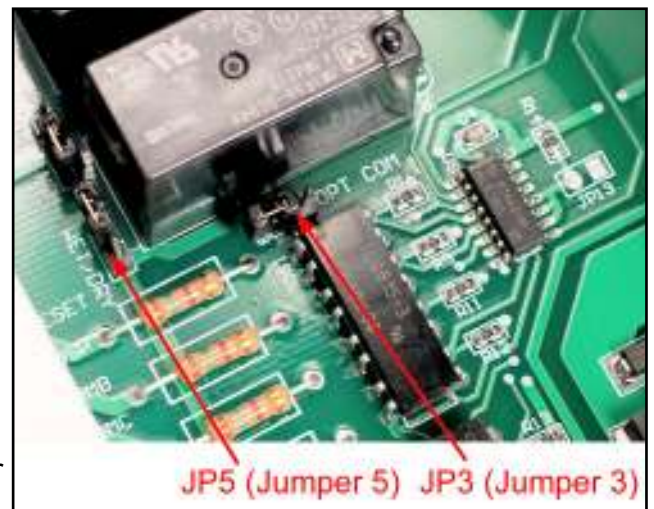

7. To remove each jumper from it's current position, grasp it gently with a pair of tweezers (as shown) or needlenose (long nose) pliers , and pull the jumper straight up until it is disengaged from the single lead it is installed on. Pull straight up on the jumper; bending the lead it is installed on will make reinstallation difficult or impossible.

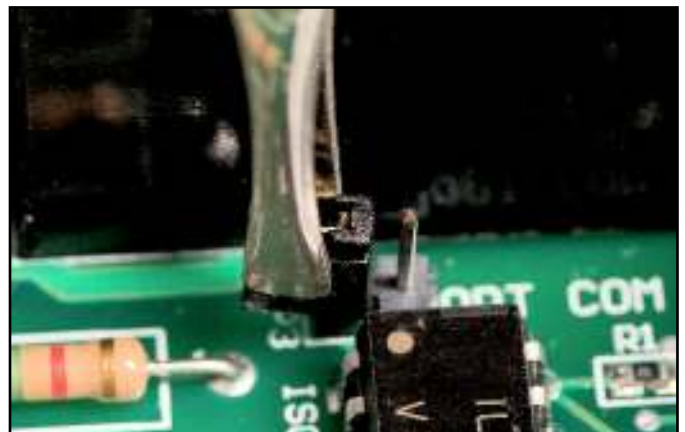

8. When the jumper is removed, the two contact pins will be exposed. These are the pins that the jumper must span when reinstalled to close the switch. This is visible as the marked item 1 for JP3 in this photo.

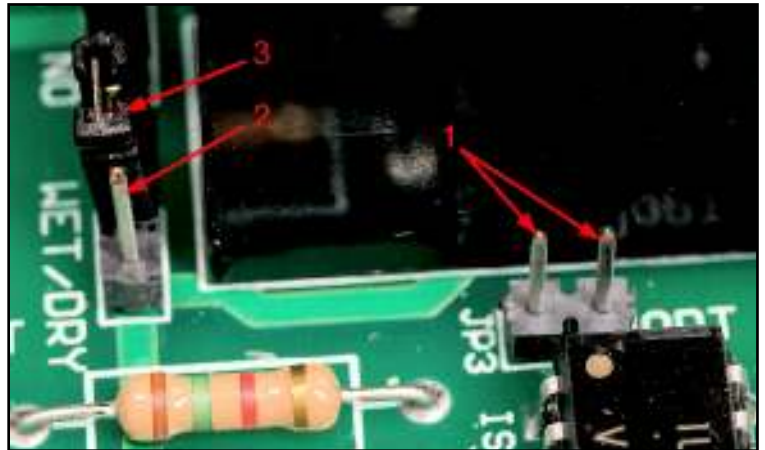

Item 2 is the exposed contact pin for JP5. Item 3 is the jumper for JP5. the two pins from JP3 are visible. JP5 has not yet been connected by using the jumper (3) to contact both JP5 contact pins. It is in the installed, open switch, position.

9. Reinstall the jumper so that the jumper spans the two vertical pins that are the contacts for that jumper switch. This provides the electrical connection that closes the switch. To do so, reposition the jumper above the two pins and gently slide the jumper straight down onto both pins. When the jumper is fully engaged by both pins, the switch is closed.



10. Repeat the jumper removal, repositioning and reinstallation process used for the JP3 jumper for the JP5 jumper.
11. Reposition the front side of the unit case and reinstall the four (4) screws that secure it to the rest of the case.
12. The internal power supply will now provide power for the switches.

Table 2 - Jumpers JP3 and JP 5 Closed - Current Flows Through Them

<u>Connector Use</u>	<u>Connector Letter</u>	<u>Minimum & Maximum Ratings</u>
Unused	A	No Connection
Unused	B	No Connection
Ground (DC)	C	System DC Ground
Output in Cycle	D	NPN sinking output, see Note A for this table.
Unused	E	Not Connected
Remote Batch Reset	F	12 VDC to 24 VDC optically isolated input, grounded to pin "R" of this connector.
Remote Suspend	G	12 VDC to 24 VDC optically isolated input, grounded to pin "R" of this connector.
Remote Parameter B	H	12 VDC to 24 VDC optically isolated input, grounded to pin "R" of this connector.

Remote Parameter C	J	12 VDC to 24 VDC optically isolated input, grounded to pin “R” of this connector.
Remote Parameter D	K	12 VDC to 24 VDC optically isolated input, grounded to pin “R” of this connector.
Cycle Accept (Relay)	L	Switch contact to “P” of this connector.
Batch Accept (Relay)	M	Switch contact to “P” of this connector.
Reject (Relay)	N	Switch contact to “P” of this connector.
24 VDC Relay Common	P	24 VDC power output maximum. See Note B for this table.
Remote Input Common	R	Common System DC Ground for: F, G, H, J and K
DC Ground		
Cycle Accept (NPN)	S	NPN sinking output, see Note A for this table.
Batch Accept (NPN)	T	NPN sinking output, see Note A for this table.
Reject (NPN)	U	NPN sinking output, see Note A for this table.
Suspend (NPN)	V	NPN sinking output, see Note A for this table.

Note A for Table 2:

Maximum power must not exceed 1.5W combined.

Formula: Volts * Amperes * number of inputs < 1.5 Watts

Maximum individual input: 24 VDC at 60 mA

Note B for Table 2:

No external power source should be connected to the relay contacts.

Maximum combined current draw (useage) should not exceed 400 mA at 24 VDC.

WESTEC[®] - Sales & Services In India

Office No. 12, 1st Floor, Hermes Atrium,
B wing, Plot 57, Sector – 11,
CBD Belapur, Navi Mumbai – 400 614

Mob: 9821 0327 20 | Tel:+91-22-2756 6533
Telefax: +91-22-2756 6534 | Website - <http://westec-india.com/>
E-mail: westecnavimumbai@vsnl.net