



TOOLS ENGINEERED TO PERFORM

Kwik-Lok Temporary Fastener

PLIER-OPERATED TEMPORARY FASTENER

A diversity of plier actuated clamps for precise holding of materials

K The K-type sheet holder clamp is the standard KWIK-LOK clamp. It is pliers-actuated, spring loaded and steel bodied; it is effective for most space requirements.



KK The KK-type sheet holder clamp is designed for those space requirements which prohibit the use of the standard K-type clamp. The KK-type is a miniature clamp, with a shorter overall body and special effectiveness for more confined areas.



K/KEL The KL and KEL-type clamps are standard K-type clamps with an extended grip range.



KHD The KHD clamp is designed specifically for heavier applications requiring an extended grip range not available in the standard K through KL series of sheet metal holders.



HOW TO SELECT A PART NUMBER

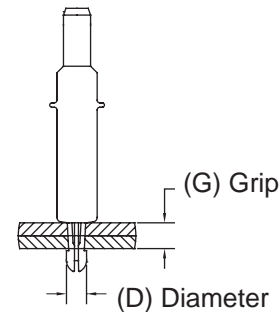
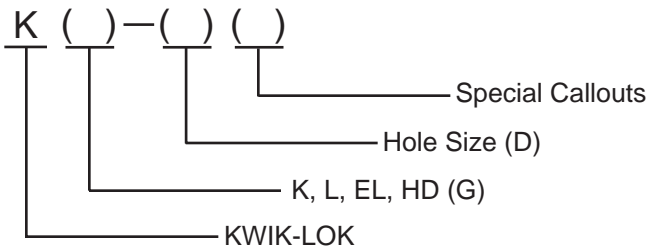

KT The KT is a variation of the standard K series. It has a pilot with which to index into holes through templates or outer material thicknesses.

HOW TO DETERMINE A TEMPLATE CLAMP PART NUMBER (K-KL SERIES)

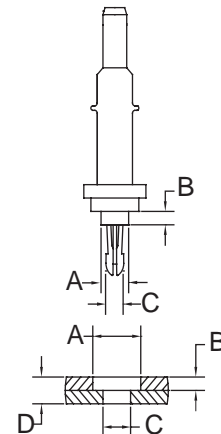
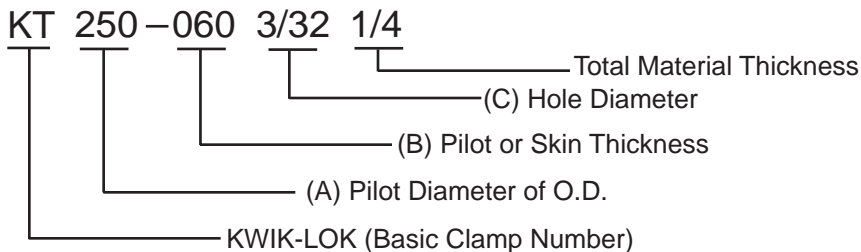

WESTEC[®] - Sales & Services In India

Office No. 12, 1st Floor, Hermes Atrium,
B wing, Plot 57, Sector – 11,
CBD Belapur, Navi Mumbai – 400 614

Mob: 9821 0327 20 | Tel:+91-22-2756 6533
Telefax: +91-22-2756 6534 | Website - <http://westec-india.com/>
E-mail: westecnavimumbai@vsnl.net

POWER-OPERATED & MANUAL TEMPORARY FASTENERS

FREE WHEELING

POWER - HEX NUT TYPE KHNS KHN KHNL KHNK



For high production applications that require a consistent, uniform clamping force. Pneumatic driven with the Power Nut Runner KNR2000 (pg 5), this time-saving fastener is well suited for both metallic and composite materials.

MANUAL - WING NUT TYPE KWNS KWN KWNL KWNK



For low production rates and high-clamping force applications. Because this fastener is manually controlled, the clamping force can range from zero to 300 lbs. Well-suited for all types of metallic and composite materials.

HOW TO SELECT PART NUMBER

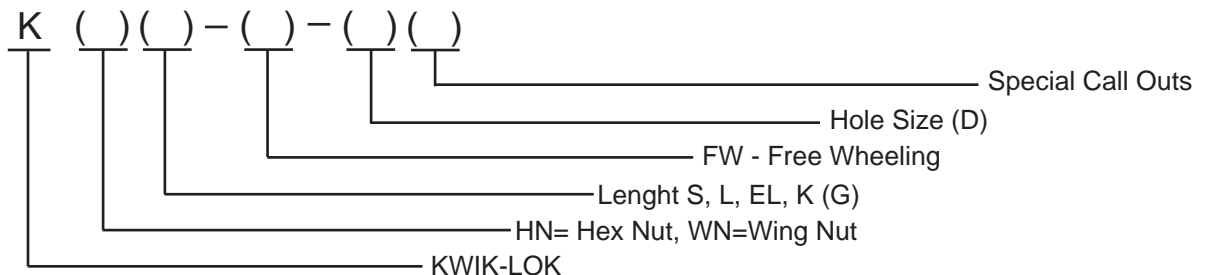
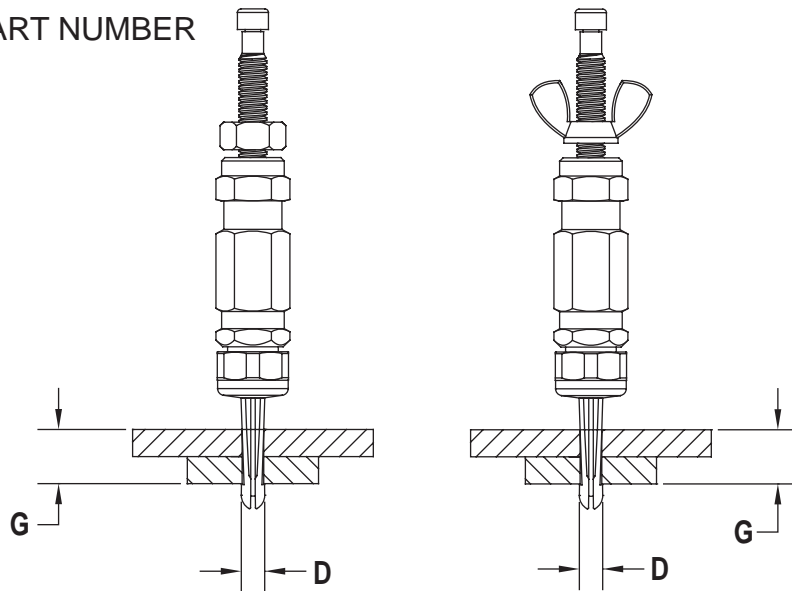

**POWER-OPERATED
TEMPORARY FASTENERS**

ORDERING INFORMATION

HEX NUT PART NO.	CROSS REFERENCE EQUIVALENT	COLOR CODE	G (grip)	D (diameter)	DRILL SIZE
KHNS-FW-3/32	HNXS-SF-3/32	silver	0-5/16"	3/32"	#40
KHNS-FW-1/8	HNXS-SF-1/8	copper		1/8"	#30
KHNS-FW-5/32	HNXS-SF-5/32	black		5/32"	#20
KHNS-FW-3/16	HNXS-SF-3/16	brass		3/16"	#10
KHNS-FW-1/4	HNXS-SH/4	copper		1/4"	1/4"
KHN-FW-3/32	HNX-SF-3/32	silver	0- 1/2"	3/32"	#40
KHN-FW-1/8	HNX-SF-1/8	copper		1/8"	#30
KHN-FW-5/32	HNX-SF-5/32	black		5/32"	#20
KHN-FW-3/16	HNX-SF-3/16	brass		3/16"	#10
KHN-FW-7/32	HNX-SF-7/32	silver		7/32"	7/32"
KHN-FW-1/4	HNX-SF-1/4	copper		1/4"	1/4"
KHN-FW-5/16	HNX-SF-5/16	black		5/16"	5/16"
KHNL-FW-3/32	HNXL-SF-3/32	silver	0-1"	3/32"	#40
KHNL-FW-1/8	HNXL-SF-1/8	copper		1/8"	#30
KHNL-FW-5/32	HNXL-SF-5/32	black		5/32"	#20
KHNL-FW-3/16	HNXL-SF-3/16	brass		3/16"	#10
KHNL-FW-7/32	HNXL-SF-7/32	silver		7/32"	7/32"
KHNL-FW-1/4	HNXL-SF-1/4	copper		1/4"	1/4"
KHNL-FW-5/16	HNXL-SF-5/16	black		5/16"	5/16"
KHNEL-FW-3/32	HNXEL-SF-3/32	silver	1/2" -1 1/2"	3/32"	#40
KHNEL-FW-1/8	HNXEL-SF-1/8	copper		1/8"	#30
KHNEL-FW-5/32	HNXEL-SF-5/32	black		5/32"	#20
KHNEL-FW-3/16	HNXEL-SF-3/16	brass		3/16"	#10
KHNEL-FW-1/4	HNXEL-SF-1/4	copper		1/4"	1/4"
KHNEL-FW-5/16	HNXEL-SF-5/16	black		5/16"	5/16"
KHNK-FW-1/8	HNXK-SH-1/8	copper	1 1/2" - 2 1/2"	1/8"	#30
KHNK-FW-5/32	HNXK-SF-5/32	black		5/32"	#20
KHNK-FW-3/16	HNXK-SF-3/16	brass		3/16"	#10
KHNK-FW-1/4	HNXK-SH-1/4	copper		1/4"	1/4"
KHNK-FW-5/16	HNXK-SF-5/16	black		5/16"	5/16"

Special Callouts AL= Aluminum Body BO = Black Oxide AC = Aluminum Cap C = Plastic Cap

**MANUAL-OPERATED
TEMPORARY FASTENERS**

ORDERING INFORMATION

WING NUT PART NO.	CROSS REFERENCE EQUIVALENT	COLOR CODE	G (grip)	D (diameter)	DRILL SIZE
KWNS-FW-3/32	WNXS-3/32	silver	0-5/16"	3/32"	#40
KWNS-FW-1/8	WNXS-1/8	copper		1/8"	#30
KWNS-FW-5/32	WNXS-5/32	black		5/32"	#20
KWNS-FW-3/16	WNXS-3/16	brass		3/16"	#10
KWNS-FW-1/4	WNXS-1/4	copper		1/4"	1/4"
KWN-FW-3/32	WNX-3/32	silver	0- 1/2"	3/32"	#40
KWN-FW-1/8	WNX-1/8	copper		1/8"	#30
KWN-FW-5/32	WNX-5/32	black		5/32"	#20
KWN-FW-3/16	WNX-3/16	brass		3/16"	#10
KWN-FW-7/32	WNX-7/32	silver		7/32"	7/32"
KWN-FW-1/4	WNX-1/4	copper		1/4"	1/4"
KWN-FW-5/16	WNX-5/16	black		5/16"	5/16"
KWNL-FW-3/32	WNXL-3/32	silver	0-1"	3/32"	#40
KWNL-FW-1/8	WNXL-1/8	copper		1/8"	#30
KWNL-FW-5/32	WNXL-5/32	black		5/32"	#20
KWNL-FW-3/16	WNXL-3/16	brass		3/16"	#10
KWNL-FW-7/32	WNXL-7/32	silver		7/32"	7/32"
KWNL-FW-1/4	WNXL-1/4	copper		1/4"	1/4"
KWNL-FW-5/16	WNXL-5/16	black		5/16"	5/16"
KWNEL-FW-3/32	WNXEL-3/32	silver	1/2" - 1 1/2"	3/32"	#40
KWNEL-FW-1/8	WNXEL-1/8	copper		1/8"	#30
KWNEL-FW-5/32	WNXEL-5/32	black		5/32"	#20
KWNEL-FW-3/16	WNXEL-3/16	brass		3/16"	#10
KWNEL-FW-1/4	WNXEL-1/4	copper		1/4"	1/4"
KWNEL-FW-5/16	WNXEL-5/16	black		5/16"	5/16"
KWNK-FW-1/8	WNXK-1/8	copper	1 1/2" - 2 1/2"	1/8"	#30
KWNK-FW-5/32	WNXK-5/32	black		5/32"	#20
KWNK-FW-3/16	WNXK-3/16	brass		3/16"	#10
KWNK-FW-1/4	WNXK-1/4	copper		1/4"	1/4"
KWNK-FW-5/16	WNXK-5/16	black		5/16"	5/16"

Special Callouts AL= Aluminum Body BO = Black Oxide AC = Aluminum Cap C = Plastic Cap

**POWER-NUT RUNNER
AND DRILL STOPS****POWER NUT RUNNER
KNR2000**

A simple to operate, rugged power tool for installation and removal of all power operated fasteners. Quiet precise and made in the U.S.A.

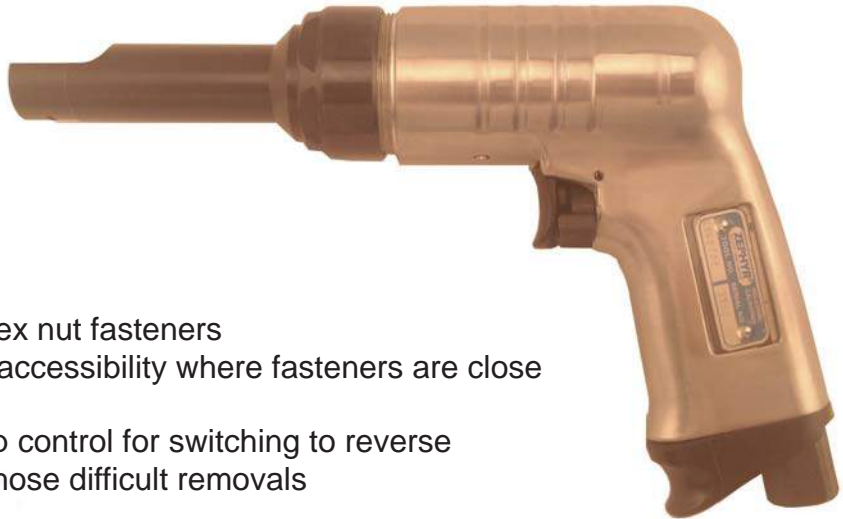

- Heavy duty, yet light weight
- Simple to insert and remove hex nut fasteners
- Small nose piece allows easy accessibility where fasteners are close together
- Reversible motor with finger tip control for switching to reverse
- Greater torque in reverse for those difficult removals
- Air pressure 85 - 100 PSI
- Torque 35 in. lbs. max.
- Clamping force up to 360 lbs.
- Available with optional adjustable internal torque control

**KDS
DRILL STOP**

KWIK-LOK manufacturers a unique multipurpose tool designed to reduce drill bit breakage. These drill stops have a coiled spring to cushion the drill break-through.

Rounded smooth face eliminates marking and prevents the chuck jaws from marring the surface.

**DRILL STOP ORDERING INFORMATION**

PART NO	EQUIVALENT	COLOR CODE	DRILL SIZE
KDS 50	DS 50	black	#50
KDS 40	DS 40	zinc	#40
KDS 30	DS 30	copper	#30
KDS 28	DS 28	zinc	#28
KDS 21	DS 21	black	#21
KDS 20	DS 20	zinc	#20
KDS 12	DS 12	brass	#10
KDS 10	DS 10	brass	#10
KDS 1/4	DS 1/	copper	1/4"
KDS 5/16	DS 5/16	copper	5/16"

NOTE: Other sizes available on request.



**SIDE GRIP
& CLAMP**

**KSG
SIDE GRIPS**

Pliers operated edge klamps hold materials together where no holes are provided. Ideal for bonding, gluing and sealants.

SIDE GRIP ORDERING INFORMATION

PART NO.	EQUIVALENT	COLOR CODE	MATERIAL THICKNESS
KSG 1/2" x 1/2"	SG 1/2" x 1/2"	Copper	0 - 1/2"
KSG 3/4" x 1/2"	SG 3/4" x 1/2"	Brass	0 - 3/4"
KSG 1/2" x 1"	SG 1/2" x 1"	Copper	0 - 1/2"
KSG 3/4" x 1"	SG 3/4" x 1"	Brass	0 - 3/4"

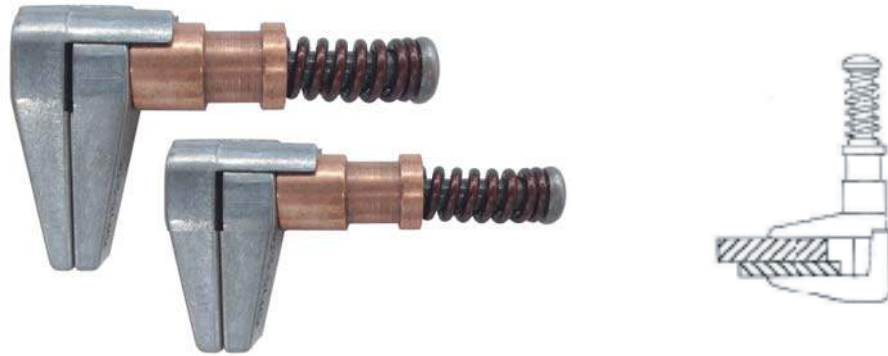

HANDI-KLAMPS

Zephyr Handi-Klamps are a versatile tool for clamping a wide range of surfaces, shapes, thicknesses and materials. Handi-Klamps are ideal for holding the

PART NO.	EQUIVALENT	CLAMPING CAPACITY	JAW DEPTH
K-1	W-1	0 - 5/16"	1"
K-2	W-2	0 - 5/16"	1 - 1/2"



Zephyr Kwik-Lok Temporary Fasteners kits

**ZKLS-1****ZKLS-2****ZKLS-3**

Zephyr offers a selection of Kwik-Lok temporary fasteners in convenient kit form. Each kit consists of Zephyr temporary fasteners, K-200 pliers, and a carrying case.

KIT CONTENTS

ZKLS-1: Includes pliers, two ½" x 1" edge grip clamps, one each of hole clamps in sizes 3/32", 1/8", 3/16", ¼", plastic carrying case.

ZKLS-2: Includes pliers, ten each of hole clamps in sizes 3/32", 1/8", 5/32", 3/16", ¼", plastic carrying case.

ZKLS-3: Includes pliers, six each of side clamps in sizes ½" x 1", and ¾" x 1", plastic carrying case.

K-200
Kwik-Lok Pliers

Zephyr's new K-200 is the only "temporary fastener" pliers hot forged from high carbon steel and heat-treated to exacting specifications. This new process offers increased life, and significantly reduces breakage. The K-200 is designed for minimum hand-reach, with new ergonomic "soft-grip" handles. The K-200 is compatible with all Cleco-style spring-loaded temporary fasteners.

Order Part Number: K-200

KBN Bar Nut

Manually Operated Temporary Fastener

Part No.	Cross Ref. Equivalent	Color Code	G(grip)	D(diel.)	Drill Size
KBNS-FW-3/32	BNXS- 3/32	silver	0-5/16"	3/32"	#40
KBNS-FW-1/8	BNXS- 1/8	copper		1/8"	#30
KBNS-FW- 5/32	BNXS- 5/32	black		5/32"	#20
KBNS-FW- 3/16	BNXS- 3/16	brass		3/16"	#10
KBNS-FW-1/4	BNXS- 1/4	copper		1/4"	1/4"
KBN-FW- 3/32	BNX- 3/32	silver	0-1/2"	3/32"	#40
KBN-FW- 1/8	BNX- 1/8	copper		1/8"	#30
KBN-FW- 5/32	BNX- 5/32	black		5/32"	#20
KBN-FW- 3/16	BNX-3/16	brass		3/16"	#10
KBN-FW- 7/32	BNX- 7/32	silver		7/32"	7/32"
KBN-FW- 1/4	BNX- 1/4	copper		1/4"	1/4"
KBN-FW- 5/16	BNX- 5/16	black		5/16"	5/16"
KBNL-FW- 3/32	BNXL- 3/32	silver	0-1"	3/32"	#40
KBNL-FW- 1/8	BNXL- 1/8	copper		1/8"	#30
KBNL-FW- 5/32	BNXL- 5/32	black		5/32"	#20
KBNL-FW- 3/16	BNXL- 3/16	brass		3/16"	#10
KBNL-FW- 7/32	BNXL- 7/32	silver		7/32"	7/32"
KBNL-FW- 1/4	BNXL- 1/4	copper		1/4"	1/4"
KBNL-FW- 5/16	BNXL- 5/16	black	5/16"	5/16"	
KBNEL-FW- 3/32	BNXEL- 3/32	silver	1/2- 1 1/2"	3/32"	#40
KBNEL-FW- 1/8	BNXEL- 1/8	copper		1/8"	#30
KBNEL-FW- 5/32	BNXEL- 5/32	black		5/32"	#20
KBNEL-FW- 3/16	BNXEL- 3/16	brass		3/16"	#10
KBNEL-FW- 1/4	BNXEL- 1/4	copper		1/4"	1/4"
KBNEL-FW- 5/16	BNXEL- 5/16	black		5/16"	5/16"
KBNK-FW-1/8	BNXK- 1/8	copper	1 1/2-21/2"	1/8"	#30
KBNK-FVI-5/32	BNXK- 5/32	black		5/32"	#20
KBNK-FW-3/16	BNXK- 3/16	brass		3/16"	#10
KBNK-FW-1/4	BNXK- 1/4	copper		1/4"	1/4"
KBNK-FW-5/16	BNXK- 5/16	black		5/16"	5/16"

This temporary fastener is designed for low production and high clamping force applications.

The bar nut design enables the operator to apply the greatest amount of clamping force in a manual operation.

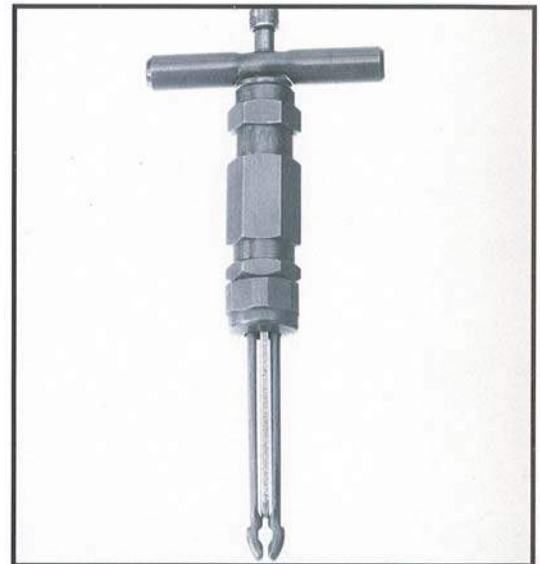

Special Callouts AL= Aluminum Body BO =Black Oxide AC =Aluminum Cap C=Plastic Cap

Represented By:

Zephyr products are designed to be safe under proper working conditions. Be sure that you know the proper way to use a tool before working with it. We recommend the wearing of eye protection when using any hand or pneumatic tool or machine shop tool.

Keep your tools clean, lubricated, inspect them from time to time, and replace worn or damaged tools. The normal cost will be more than offset by reduction of mistakes and savings on rework

Kwik-Lok
Temporary Fastener**PROTECTIVE CAPS FOR
Pliers Operated Fasteners****K, KL, KEL**

PART No.	NOMINAL SIZE	COLOR
KN23-3/32F	3/32	GRAY
KN23-1/8F	1/8	ORANGE
KN23-5/32F	5/32	BLACK
KN23-3/16F	3/16	BLUE
KN24-7/32F	7/32	GREEN
KN24-1/4F	1/4	YELLOW

KHD, KK

PART No.	NOMINAL SIZE	COLOR
KN24-3/32F	3/32	GRAY
KN24-1/8F	1/8	ORANGE
KN24-5/32F	5/32	BLACK
KN24-3/16F	3/16	BLUE
KN24-7/32F	7/32	GREEN
KN24-1/4F	1/4	YELLOW

**PROTECTIVE CAPS FOR
Power Operated & Manual Temporary
Fasteners****POWER-HEX NUT TYPE****KHNS, KHN, KHNL, KHNEL, KHNK****MANUAL-HEX NUT TYPE****KWNS, KWN, KWNL, KWNEL, KWNK**

PART No.	NOMINAL SIZE	COLOR
KN25-4F	3/32	GRAY
KN25-2F	1/8	ORANGE
KN25-5F	5/32	BLACK
KN25-1F	3/16	BLUE
KN25-7F	7/32	GREEN
KN25-3F	1/4	YELLOW
KN25-6F	5/16	RED

WESTEC[®] - Sales & Services In India

Office No. 12, 1st Floor, Hermes Atrium,
B wing, Plot 57, Sector – 11,
CBD Belapur, Navi Mumbai – 400 614

Mob: 9821 0327 20 | Tel:+91-22-2756 6533
Telefax: +91-22-2756 6534 | Website - <http://westec-india.com/>
E-mail: westecnavimumbai@vsnl.net